

GAS GAS



QUAD 250

***MANUAL DEL USUARIO
SERVICE MANUAL
MANUEL D'ENTRETIEN
LIBRETTO D'USO***



QUAD 250

SERVICE MANUAL

Brief introduction

250 EC QUAD embodies the experience and essence of world motorcycle technology. It adopts single-cylinder four-stroke air -cooled engine newly developed by our company, and employs the devices of carburettor carburetor, wet automatic centrifugal clutch, five-speed shifting, through driving, reverse driving hand pulled recoil starter and electric-starter in combination, CDI electric ignition, pressure splash lubrication system, etc, which are good in performance. This QUAD is novel and bright in design, having moved, streamlined model and luxury decoration design, and it meet the national standard in noise and dirt drainage, specially it embodies the great power, reliability, endurance, being an ideal transportation facility for QUAD fans.

The correct operation and maintenance are the prerequisites at your safety riding of the QUAD, and also can reduce the fault of the QUAD and keep its best performance. So please read this manual to understand its basic operation, repair and maintenance methods. The information contained here in all relates to the QUAD of the current design and is subject to changes by our company according to the demands of market and users without notice. If you have any questions, please consult with our motorcycle dealer. We are welcome for your precious advice and suggestions. Our company has established many service centers (stations, points), with specially-trained technical personnel in operation and maintenance, please contact with our motorcycle dealer and service center (stations, points). Our company consistently adheres to the principle of quality first users upmost, reputation foremost and be ready to provide you with high quality service.

IMPORTANT INFORMATION FOR OPERATION

- WARNING** Injury or death could be result from failure to follow WARNING instructions when you are operating inspecting or repairing the QUAD.
- CAUTION** A CAUTION indicates special precautions that must be taken to avoid damage to the QUAD.
- NOTE** A NOTE provides information can make your operation in the QUAD easier or clearer.

Content

Safety information.....	5	Spring preload adjustment.....	18
Description and machine identification	9	Pre-operation checkes.....	19
Control functions.....	11	Front and rear brakes	19
Main switch.....	11	Fuel.....	20
Indicator lights	11	Engine oil.....	21
Handlebar switches	11	Lubrication oil of gear case.....	21
Start switches	11	Throttle lever.....	21
Light switches	12	Fittings and Fasteners	21
Throttle lever.....	13	Lights	21
Speed limiter.....	13	Switches	21
Front brake lever	14	Battery	21
Rear brake pedal and lever	14	Tires.....	22
Parking brake	15	How to measure tire pressure	22
Shift pedal.....	16	Tire wear limit	23
Drive select lever	16	Operation.....	24
Recoil statrer	16	Starting an engine	24
Fuel tank cap	17	Starting a cold engine.....	24
Fuel cock	17	Starting a warm engine.....	24
Seat	17	Prewarming	24
Storage box	18	Drive select lever operation and reverse driving	25
Front carrier	18	Shifting.....	26
Rear carrier.....	18	To start out and accelerate.....	26
Rear shock absorber	18	To decelerate.....	26
		Engine breakrin	27

Accessories	28	Front brake lever free play adjustment	45
Loading	28	Rear brake adjustment	46
Ride with care	28	Clutch adjustment	47
Speed limit valve	30	Cable inspection and lubrication	48
Exhaust silencer	30	Brake and shift pedal/brake lever lubrication	48
Turning	31	Steering vertical tube lubrication	48
Climbing slope	32	Wheel removal	48
Riding downhill	33	Wheel installation	49
Crossing depression	33	Fuse replacement	50
Crossing through shallow water	33	Replacing the headlight bulb	51
Riding over rough terrain	34	Spark arrester cleaning	52
Slipping	34	Cleaning and storage	52
Periodic maintenance and adjustment	35	Cleaning	52
Operation manual and tool kit	35	Storage	53
Periodic maintenance /Lubrication	36	Main data and specification	54
Engine oil	38	Maintenance record	56
Lubrication oil of gear case	40	Electric wiring diagram	57
Replace of lubrication oil of gear case	40		
Spark plug inspection	41		
Air filter cleaning	42		
Carburetor adjustment	43		
Idle speed adjustment	43		
Valve clearance adjustment	44		
Throttle lever adjustment	44		
Front and rear brake shoe inspection	44		

SAFETY INFORMATION

This operation manual includes important safety and maintenance information. When reselling the QUAD TO THE NEXT BUYER. The operation manual should be passed on together with it because the next user also needs the manual. Please read the manual carefully before driving the new. If failed to conform the requirements described in the manual. It will be easy to cause injuries and deaths.

WARNING

- Read this manual carefully and follow the operating procedures and methods described in this manual.
- Never operate an QUAD without proper training or instruction.
- A child under 16 years old should never operate an QUAD. Never allow drive of an QUAD by an individual person if he or she does not have the abilities to operate it safely.
- Always avoid driving an QUAD on any paved surfaces, including sidewalks, driveways, parking lots and streets.
- Never operate an QUAD in any public street, road or highway.even a dirt or gravel one.
- Never drive an QUAD without wearing an approved motorcycle helmet that fits properly. You should also wear eye protection (goggles or face shield), gloves, boots, long-sleeved shirt or jacket.and long pants.
- Never consume alcohol or drugs before or while operating this QUAD.
- Never operate at speeds too fast.always drive at low speed on dusty surface.
- Always inspect your QUAD each time you use it to make sure it is in safe operating condition. Always follow the inspection and maintenance procedures and schedules described in this manual.
- Always keep both hands on the handlebars and both feet on the footboards of the QUAD during operation.
- Never operate on excessively rough, slippery or loose terrain unless you have learned and practiced the skills necessary to control the QUAD on such terrain. Always be especially cautious on these kinds of terrain.
- Always follow proper procedures for turning as described in this manual. Practice turning at low speeds before attempting to turn at faster speeds. Do not turn at excessive speed.
- Never drive the QUAD on hills too steep for the QUAD or for your abilities. Practice on smaller hills before attempting larger hills.
- Always follow proper procedures for climbing hills as

described in this manual. Check the terrain carefully before starting up any hill. Never climb hills with excessively slippery or loose surfaces. Shift your weight forward. Never open the throttle suddenly or make sudden gear changes. Never go over the top of a hill at high speed.

- Always follow proper procedures for going down hills and for braking on hills as described in this manual. Check the terrain carefully before starting down any hill. Shift your weight backward. Never go down a hill at high speed. Avoid going down a hill at an angle that would cause the vehicle to lean sharply to one side. Go straight down the hill where possible.

- Always follow proper procedures for crossing the side of a hill as described in this manual. Avoid hills with excessively slippery or loose surfaces, shift your weight to the uphill side of the QUAD. Never attempt to turn the QUAD around on any hill until you have mastered the turning technique described in this manual on level ground. Avoid crossing the side of a steep hill if possible.

- Avoid crossing the steep hills.

- Always use proper procedures if you stall or roll backwards when climbing a hill. To avoid stalling, use proper gear and maintain a steady speed when climbing a hill. If you stall or roll backwards. Follow the special

procedure for braking described in this manual.

- Always check for obstacles before operating in a new area. Never attempt to operate over large obstacles, such as large rocks or fallen trees. Always follow proper procedures when operating over obstacles as described in this manual.

- Always be careful when skidding or sliding. Learn to safely control skidding or sliding by practicing at low speeds and on level, smooth terrain. On extremely slippery surfaces, such as ice. Go slowly and be very cautious in order to reduce the chance of skidding or sliding out of control.

- Never operate an QUAD in fast flowing water or in water deeper than that recommended in this manual. Remember that wet brakes may have reduced stopping ability. Test your brakes after wiping water away. If necessary, apply them several times to let friction dry out the linings.

- Always be sure there are no obstacles or people behind you when operating in reverse. When it is safe to proceed in reverse, go slowly. Always use the size and type tires specified in this manual. Always maintain proper tire procedure as described in this manual.

- Never modify an QUAD through improper installation or use of accessories.

- Never exceed the stated load capacity for an QUAD. Cargo should be properly distributed and securely attached.
- Reduce speed and follow instructions in this manual for carrying cargo or pulling a trailer. Allow greater distance for braking.
- Improper handling of gasoline can cause fire and can cause injuries and deaths and other serious accident. So do not refuel right after the engine has been running and is still every hot. Never refuel while smoking, or while in the vicinity of sparks, open flames, or other sources of ignition, when transporting the machine in another vehicle, be sure it is kept upright and that the fuel cock is in the "OFF" position, otherwise fuel may leak out of the carburetor or fuel tank.

Starting or running the engine in a closed area will cause the breakdown. And exhaust fumes are poisonous and may cause loss of consciousness and death within a short time. Always operate your machine in an area with adequate ventilation.

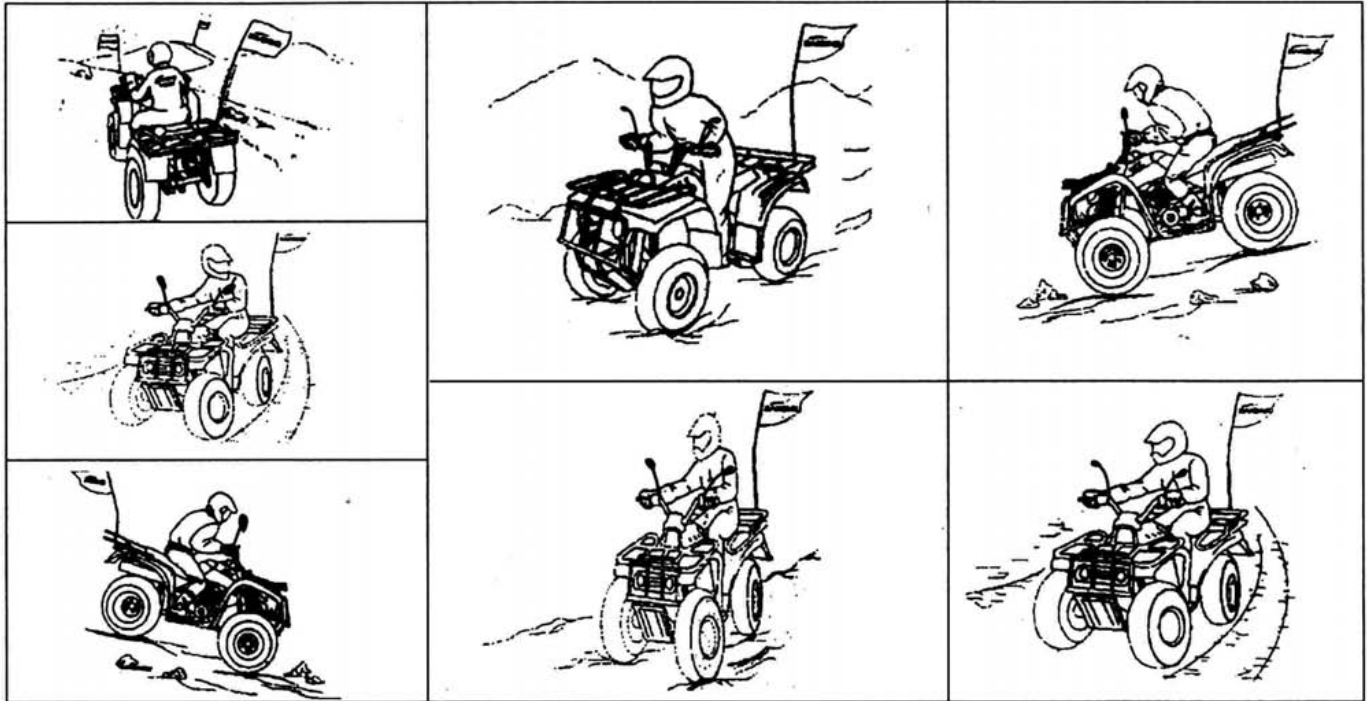

DESCRIPTION AND MACHINE IDENTIFICATION

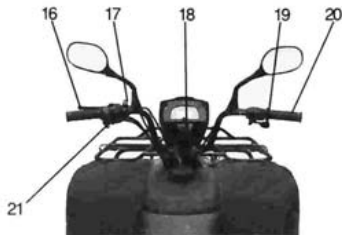
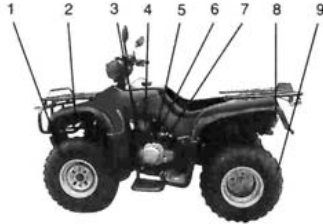

1. Front wheel
2. Headlight
3. Drive select lever
4. Shift pedal
5. Fuel cock
6. Recoil starter
7. Starter(choke)
8. Taillight
9. Rear wheel
10. Rear carrier
11. Spark arrester
12. Seat
13. Fuel tank cap
14. Brake pedal
15. Front carrier
16. Rear brake lever
17. Parking brake
18. Main switch
19. Throttle lever
20. Front brake lever
21. Handlebar switch

The machine you have purchased may differ slightly from those shown in the figures of this manual for progress or other change.

Identification numbers record

When ordering spare parts from a our dealer or for reference in case the vehicle is stolen record, vehicle identification number in the spaces provided for assistance.

1. VEHICLE IDENTIFICATION NUMBER:

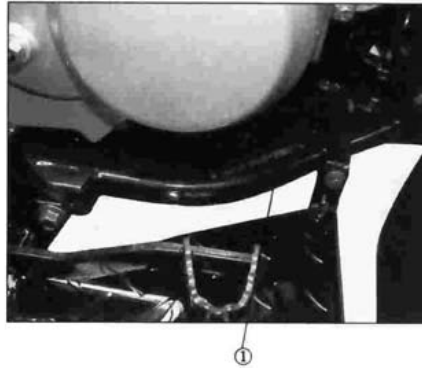

Vehicle identification number

The vehicle identification number is stamped on crosstube of pedestal.

CONTROL FUNCTIONS

Main switch

Functions of the respective switch positions are as follows:

ON:

Engine can be started only at this position and the headlight and taillight come on when the light switch is on.

OFF:

All electrical circuits are switched off. The key can be removed in this position.

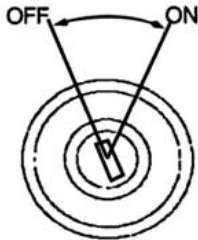

Indicator lights

Reverse indicator light "R"

This indicator light comes on when the transmission is in reverse. The light is blue in color.

Neutral indicator light " N "

This indicator light comes on when the transmission is in neutral.

High beam indicator light " "

This light is yellow in color. It comes on when the headlight and high beam light is on.

Handlebar switches

Engine stop switch

Make sure that the engine stop switch is in the "  " position. The engine stop switch controls ignition and can be used at all times to stop the engine, especially in an emergency.

The engine will not start or run when the engine stop switch is turned to "  ".

Start switch

The starter motor cranks the engine when this switch is pushed.

See starting instructions prior to starting engine (see page for details).

If the starter switch is pushed with the main switch "⊙" and the engine stop switch "⊗", the starter motor will be activated but the engine will not start. To start the engine, be sure to set the engine stop switch at "⊙".

Lights switch "LIGHTS"

Turn the switch to "☰" for the low beam and taillight.
for the high beam

Turn the switch to "☷" for the high beam and taillight.

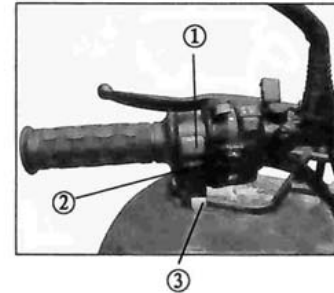

1. Lights switch "LIGHTS"
2. Engine stop switch "⊙" "⊗"
3. Start switch "⚡"

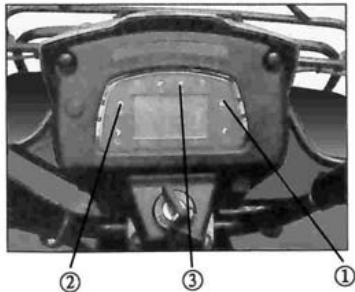

1. Neutral indicator light "N"
2. Reverse indicator light "R"
3. High beam indicator light "☷"

Throttle lever

Once the engine is running .movement of the throttle lever will increase the engine speed.Adjust the speed of the machine by changing the throttle position.Because the throttle is spring-loaded,the machine will decelerate.and the engine will return to an idle any time the hand is removed from the throttle lever.Before starting the engine .check the throttle to be sure it is operating smoothly .Make sure it returns to the idle position as soon as the lever is released. Check the operation of the throttle lever before starting the engine.If it does not work smoothly.check for the cause. Correct the problem before riding the QUAD. Consult a our dealer if you can't find or solve the probem yourself.

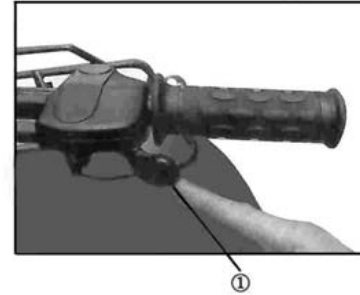

1 .Throttle lever

Speed limiter

The speed limiter keeps the throttle from fully opening, even when the throttle lever is pushed to the maximum. Screwing in the adjusting screw limits the maximum engine power available and decreases the maximum speed of the QUAD.

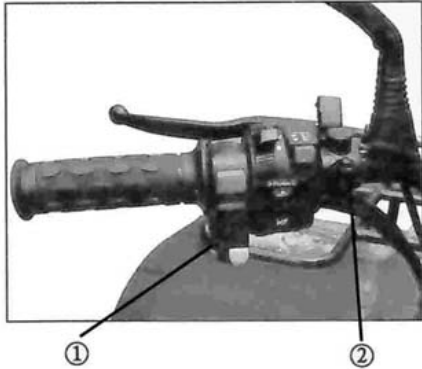

1. Locknut
2. Adjusting screw a.12mm (047in)

CAUTION

Do not turn the speed adjusting screw out more than 12mm. Always make sure the throttle lever free play is adjusted to 3-5mm.

Front brake lever

The front brake lever is located on the right handlebar. Pull it toward the handlebar to apply the front brake.

Rear brake pedal and lever

The brake pedal is located on the right side of the machine and the brake lever is located on the left handlebar. Pull the lever toward the handlebar or tread slow the pedal to apply the rear brake.

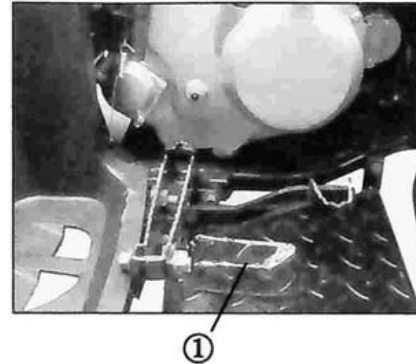

1. Rear brake pedal

Parking brake

When you have to start the engine or park the machine, especially on a slope, use the parking brake. Apply the rear brake lever and push down the lock plate to apply the parking brake, squeeze the rear brake lever to release the parking brake.

CAUTION

The QUAD could start moving unexpectedly if the parking brake is out of function before starting the engine. This could cause loss of control or a collision. The barke could overheat if you ride the QUAD without releasing the parking brake. You could lose braking performance which could cause an accident. You could also wear out the brakes prematurely.

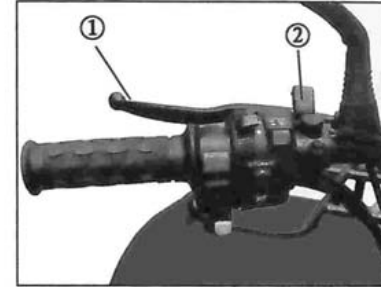

1. Rear brake lever
2. Lock plate

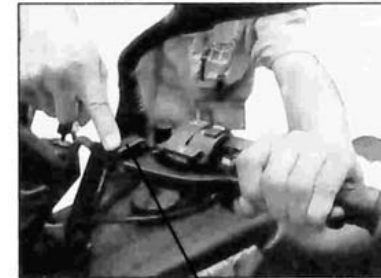

1. Lock plate

HOW TO AVOID THE HAZARD

Always set the parking brake before starting the engine. Always be sure the parking brake have been released before you begin to ride.

Shift pedal

This machine is equipped with a constant mesh 5-speed transmission. The shift pedal is located on the left side of the engine. Neutral is at the bottom position.

Drive select lever

The drive select lever is used for driving the machine either forward or in reverse. Refer to page for drive select lever operation.

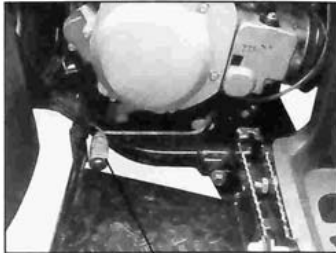

1.Shift pedal N.Neutral



1 .Drive select lever

2. Hand start lever

Recoil starter

Firmly grasp the handle and pull slightly up to engagement can be felt. Then pull forcefully, being careful not to pull the rope all the way out.

CAUTION

Don't start the engine in non-neutral or without setting the parking brake system.

Put the transmission in neutral and set the parking brake before starting the engine.

Fuel tank cap

Remove the fuel tank cap by turning it counter clockwise.

Fuel cock

The fuel cock supplies fuel from the fuel tank to the carburetor.

OFF:

If the lever is in this position, fuel will not flow. Always turn the lever to this position when the engine is not running



1. Fuel tank cap

ON:

If the lever is in this position, fuel flows to the carburetor. Normal riding is done with the lever in this position.

RES:

This indicates reserve. If you run out of fuel while riding, turn the lever to this position. After refuelling, return the fuel cock lever to the "ON" position.

Seat

To remove the seat, pull the seat lock lever upward and pull up the seat at the rear.

To install the seat, insert the lobes on the frame and push down the seat at the rear you should pay attention to make sure that the seat is securely fitted.

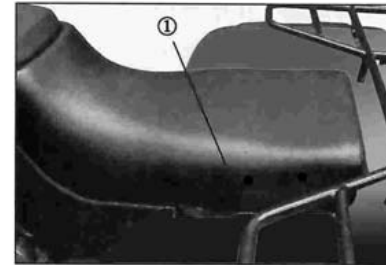

1 .Seat lock lever



Storage box

Maximum load limit: 2kg

Front carrier

Maximum load limit: 30kg

Rear carrier

Maximum load limit: 60kg

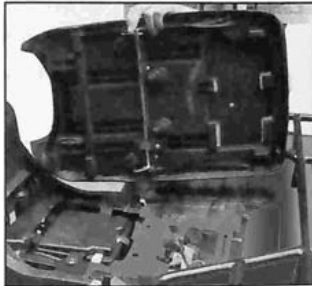

Rear shock absorber

The spring preload can be adjusted to suit the rider's weight and riding conditions.

Spring preload adjustment

To increase the spring preload turn the adjuster in direction A. To decrease the spring preload, turn the adjuster in direction B.

Standard position: B

A-Minimum(Soft)

E-Maximum(Hard)

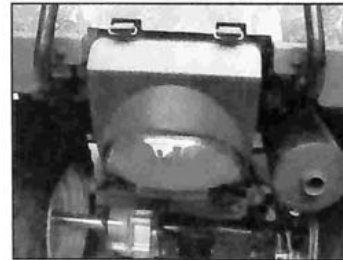

PRE-OPERATION CHECKS

Before using this machine, check the following points:

ITEM	ROUTINE	PAGE
Brakes	Check operation, condition and free play	
	Adjust if necessary	
Engine oil	Check oil level	
	Fill with oil if necessary	
Fuel tank	Check fuel level	
	Fill with fuel if necessary	
Gear oil	Check for leakage	
Throttle	Check for Draper throttle cable operation	
Wheels and tires	Check tire pressure wear and damage	
Fittings and fasteners	Check all fittings and fasteners	
Lights	Check for proper operation	
Battery	Check the voltage	

Inspect the QUAD each time you use it to make sure the QUAD is in safety operating condition. Follow the inspection and maintenance procedures and schedules described in the Operation Manual.

Front and rear brakes

Always check the brakes at the start of every side. Do

not ride the QUAD if you find any problem with the brakes. If a problem cannot be corrected by the adjustment procedures. Provided in this manual, have the QUAD inspected by a our dealer.

Check for correct free play in the brake levers and brake pedal, If the free play is incorrect adjust it see pages. Check operation of the levers and pedal They should

move smoothly and there should be a firm feeling when the brake is applied. If not, have the machine inspected by a our dealer.

Test the brakes at slow speed after starting out to make sure they are working properly. If the brakes do not provide proper braking performance, inspect the brakes for wear. See page.

Fuel

Make sure there is sufficient gasoline in the tank.

Recommended fuel: unleaded fuel

Fuel tank capacity:

Total: 12L

Reserve: 1.6L

Unleaded fuel will give a longer spark plug life and reduce maintenance cost. If unleaded gasoline is not available the leaded regular gasoline can be used.

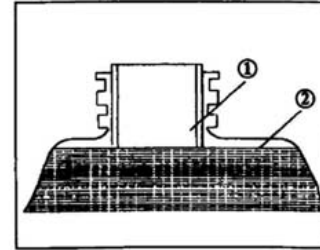

1. Brake levers and brake pedal

2. Brake operation

CAUTION

Fuel can spill, causing a fire and severe injury. Fuel will expand when it heats up if the fuel tank is overfilled. Fuel could spill out due to heat from the engine or the sun. So, do not overfill the fuel tank. Be careful. Not to spill fuel, especially on the engine or exhaust pipe. Wipe up any spilled fuel immediately. Be sure the fuel tank cap is closed securely. Do not refuel right after the engine has been running and is still very hot.

Engine oil

Make sure the engine oil is at the specified level. Add oil as necessary.(See page)

Recommended oil

SAE20W40

SAE10W30

SAE5W30

Recommended engine oil classification:

SE, SF, SG type or higher.

Oil quantity:

Periodic oil change: 1.5L

With oil filter replacement: 1.6L

Total amount: 1.8L

Lubrication oil of gear case

Make sure the lubrication oil of gear case is at the specified level. Add oil as necessary.(see page for details).

Recommended oil

SAE80 API GL Hypoid gear oil

Throttle lever

Check to see that throttle lever operates correctly. It must open smoothly and spring back to idle position

when released.Repair as necessary for proper operation.

Fittings and Fasteners

Always check the tightness of chassis fittings and fasteners before a ride.Refer to the Service . Manual for correct tightening torque.

Lights

Check the headlight and taillight to make sure they are in working condition. Repair as necessary for proper operation.

Switches

Check the Operation of the headlight switch, engine stop switch and any other switches.Repair as necessary for proper operation.

Battery

- The battery is an enclosed one and unnecessary to fill water (see page)
- Don't take off the closing bolt when charging.
- When charging,please obey the charging current and time as shown on the following table.

Charge criteria: Charge the battery with ten percent of

capacity of battery for 5 to 10 hours, or quickly charge the battery with 2A to 3A for 2 hours.

Tire

The size and type (in low pressure condition) of hollow tire used for 250 QUAD are listed below.

	Front wheel	Rear wheel
Size	AT22X7-10	AT22 x 10-10
Type	Zheng xin or wuxi	Zheng xin or wuxi

warning

Use of improper tires on this QUAD, or operation of this QUAD with improper tire pressure may increase your risk of accident.

Use of improper tires on this QUAD, or operation of this QUAD with improper tire pressure may cause loss of control.

Pay attention to choose the Size and type of used tire according to the description in the above chart and make sure that the tire pressure is normal.

2. The tires should be set to the recommended pressure.

Front 20KPa(0.20kgf/cm², 2.8psi)

Rear 25KPa(0.25kgf/cm², 3.6psi)

Check and adjust tire pressure when the tires are cold.

Tire Pressure below the minimum specified could cause the tire to dislodge from the rim under severe riding conditions. The following are minimums:

Front 17KPa(0.17kgf/cm²)

Rear 22KPa(0.22kgf/cm²)

Higher pressures may cause the tires to burst. Inflation could cause the tires to burst

How to measure tire pressure

Use the low-pressure tire gauge.

Caution:

The low-pressure tire gauge is included as standard equipment, conduct two measurements if the tire pressure and use the second reading. Dust or dirt in the gauge would cause the First reading to be incorrect. Set pressure when tires are in cold and set tire pressures to the condition following specifications:

	Recommended pressure	Minimum	Maiximum
Front	20Kpa (0.20kgf/cm ²)	17Kpa (0.17kgf/cm ²)	23Kpa (0.23kgf/cm ²)
Rear	25Kpa (0.25kgf/cm ²)	22Kpa (0.22kgf/cm ²)	23Kpa (0.28kgf/cm ²)



1. Low-pressure tire gauge:

Tire wear limit

When the tire groove decreases to 3mm due to wear.

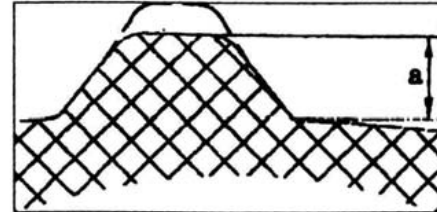

- a. 3mm (0.12 in)

OPERATION

WARNING

Never operate QUAD until you are familiar with all controls.

Read the operation Manual carefully. If there is a controls or function you do not understand, ask your our dealer.

WARNING

Never ride the QUAD in cold weather,always make sure all control cables work smoothly before you begin ridding. Please read the engine brake-in section before you operate the engine at first time.

Starting a cold engine:

1. Set the parking brake.
2. Turn the fuel lock to "ON" and the engine stop switch to ".
4. Shift the transmission into neutral.

WARNING

The engine can be started in any gear if the rear brake lever is applier. However.it is recommended to shift into neutral before starting the engine.

5. Use the starter(choke)in reference to the figure.

NOTE

If the engine fails to start release the start switch, then push the start switch again, pause a several secords before the next attempt. Each cranking should be as short as possible to preserve battery energy. Do not crank the engine more than 10 secords for each starting. If the battery is discharged, pull the recoil starer to start engine.

Starting a warm engine

The throttle should be opened slightly when starting a warm engine.

Prewarming

To get maximum engine service life, prewarm the engine before startting off. Never accelerate forcefully with a cold engine.

Drive select lever operation and reverse driving.

CAUTION

Before shifting, stop the machine and return the throttle lever to its closed position. Otherwise the transmission may be damaged.

When shifting into reverse the transmission must be in the first gear. Do not shift the Reverse Handle Bar before you make sure that the QUAD is in the First Gear or you may break the Handle Bar.

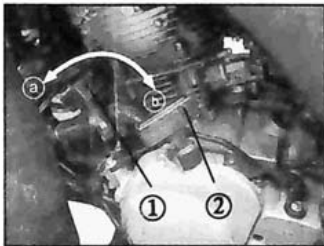

1. Reverse Handle Bar
2. Hand start lever

- a. Forward
- b. Reverse

1. Stop the machine completely and return the throttle lever to the closed position.
2. Apply the rear brake pedal.
3. Shift the transmission into first gear.
4. Press the lock-button of the Reverse Handle Bar hard into the socket the you can shift the Reverse Handle Bar. After it is moved to the proper position,

move the Handle Bar and softly to make sure the spring of the lock-button is released and the Handle Bar is locked.

5. In case the lock-button can not be released after the Handle Bar is shifted to it's position, ask the repair shop help.

NOTE

When in reverse the reverse indicator light should be on. If the light does not come on ask a our dealer to inspect the machine.

6. Check for people or obstacles behind you, then release the rear brake pedal.

7. Open the throttle lever gradually and continue to watch to the rear while backing.

WARNING

When shifting into reverse, make sure there are no obstacles or people behind you when it is safe to proceed, go slowly.

Shifting:

This machine has a 5-speed forward and 1-speed reverse transmission with centrifugal automatic clutch. To shift into neutral when driving, return the throttle lever to its original position and repeatedly depress the shift pedal until it stops .

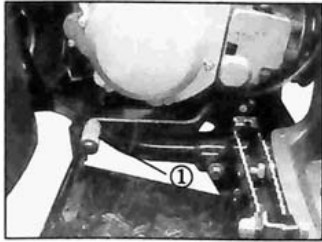

1 .Shift pedal

CAUTION

Do not coast for long periods with the engine off, and do not tow the machine a long distance. Even when gears are in neutral, the transmission is only properly lubricated when the engine is running. Inadequate lubrication may damage the transmission.

To start and accelerate:

1. Release the throttle lever.

CAUTION

- Always close the throttle while shifting gears. Otherwise, the engine and drive train may be damaged.
2. Shift into first gear and release the shift pedal.
 3. Open the throttle gradually once the machine has obtained adequate speed release the throttle lever.
 4. Shift into second gear and release the shift pedal.
 5. Open the throttle gradually. Follow the same procedure. When shifting to the next higher gear.

To decelerate:

When slowing down or stopping, release the throttle and apply the brakes smoothly and even. As you slow down, shift to a lower gear. Be sure that the engine has sufficiently slowed before engaging a low gear. Improper use of the brakes or control can cause the tires to lose traction, reducing control and increasing the possibility of an accident.

Engine break-in

There is never a more important period in the life of your machine than the period between zero and 20 hours. During this period prolonged full throttle operation or any condition which might result in excessive engine heating must be avoided after every full throttle acceleration the engine should run at lower speed for a rest so as to rid itself of the temporary build up of heat. If any abnormality is found during this period consult a our dealer.

1. 0-10 hours:

Avoid continuous operation above half throttle. Allow a cooling off period of five to ten minutes after every hour of operation. Vary the speed of the machine from time to time. Do not operate it at one set throttle position.

2. 10-20 hours:

Avoid prolonged operation above 2/4throttle revolving the machine can freely through the gears during running of engine but do not use full throttle any time.

3. After break-in

Avoid prolonged full throttle operation change speeds occasionally.

Parking

When parking, stop the engine and shift into neutral. Turn the fuel to "OFF" and apply the parking brake.



1. Lock plate

Avoid parking on hills or other inclines. If you have to park on an incline put the machine in low gear. Apply the parking brake and block the front and rear wheels with rocks or other object. Do not park the QUAD on the hills that are so steep that you could not walk up them easily.

1. Applying the brakes in low gear to stop the machine.
2. Stop the engine. With the rear brake lever and pedal applied, apply the parking brake and slowly release the rear brake pedal.

Accessories:

Pay attention to the following points.

Choose only accessories designed for you QUAD. Our dealer has a variety of genuine accessories . Choose a genuine accessory.

WARNING

1. Accessories should be rigidly and securely installed.
2. Do not install an accessory where it could interfere with your ability to control the QUAD. Examples include a heavy or bulky object attached to the handle bars which could make steering difficult an accessory that limits your ability to move around on the seat or one that limits your view. Use extra caution when riding an QUAD with accessories.

Loading

Never exceed the weight limits shown An overloaded QUAD can be unstable.

You must use common sense and good judgement when carrying cargo or towing a trailer, keep the following points in mind:

Maximum loading limit

Vehicle Loading limit (total weight of cargo rider and

accessories):165kg

Front luggage carrier:30kg

Rear luggage carrier:60kg

Tool kit: 2kg

Pulling load (total weight of trailer and cargo): 330kg

Vertical weight on trailer hook: 15kg

Do not exceed the maximum pulling weight.

Adjust the load in the trailer.

Cargo should be put as close to the center of the QUAD as possible. Put cargo at the front of the rear luggage carrier. Put the cargo on the middle position and fix it on the carrier firmly.

Make sure cargo in the trailer is loaded firmly and safety. Otherwise an accident would be happen. Make sure the load does not interfere with controls or your sighting.

Ride more slowly than you would with a load. The more weight you carry, the slower you should go. Although conditions is different, it is not allowed to exceed 2nd gear whenever you are carrying heavier loads or when towing a trailer. Allow more braking distance. A heavier vehicle takes longer to stop. Avoid making sharp turns unless at very slow speeds.

Avoid riding on hills and rough road surface. And choose terrain carefully. Extra weight will affects the

stability and operation of the QUAD.

This machine could be used to carry cargo and passengers is prohibited.

OPERATION

1. Get training if you are unexperienced.

Beginners should be trained at the guide of professional person. Drive with this QUAD with low speeds first to familiar with its performance even if you are an experienced rider do not attempt to operate at maximum performance until you are totally familiar with QUAD's performance.

2. Dress

Always wear a motorcycle helmet when riding. Also wear the following protective tools eye protection (goggles or dust-proof shield, gloves, boots long-sleeved shirt or jacket pants)

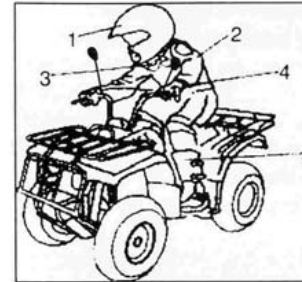

3. Do not operate after drinking alcohol or drugs containing sleeping pill composition, because operator would be slow in driving in such way.

4. Always check your QUAD each time before you use it to make sure the reliability of QUAD. Always follow the inspection and maintenance procedures in the operation manual to protect your QUAD.

5. Always select the size and type of tires specified in the operation manual for this vehicle to keep the normal tire pressure.



6. Speed limit valve

This valve is used for beginners to limit the max speed of the QUAD. Rotate the bolt clockwise to increase max speed, and rotate it counterclockwise to decrease max speed.

7. Always keep your feet on the footboards during operation otherwise your feet may contact the rear wheels.

Never attempt stunts such as wheelies or jumps.

WARNING

Don't try to show off

8. Improper installation of accessories or modification of this vehicle may cause changes in handling which in some situations could lead to an accident.

Never modify this QUAD through improper installation or use of accessories. All parts and accessories added to this vehicle should be genuine or equivalent components designed for use on this QUAD and should be installed and used according to instructions from our dealer. If you have questions consult an authorized QUAD dealer.

9. Exhaust silencer

The exhaust silencer is very hot during driving. To avoid burn, do not touch the exhaust cylinder. Park the machine where pedestrians or children can not touch it.

10. Know where you should ride

This machine is designed to drive on off-road. Riding on asphalt road may lose control.

Don't ride the QUAD on asphalt road, including sidewalks, driveways, parking lots and walk streets. Prohibit to drive the machine on any driveway, streets or highways.

Know the terrain where you ride

Ride carefully in complicated terrain, stay alert for holes, rocks or roots or roots in the terrain otherwise may cause the machine to tip over.

When riding in an area where you might not easy to be seen, such as dune and hilly land, must mount a caution flag on the machine to remind other vehicles. Do not ride in areas of forbidding pass. Do not ride on private property. Operation course

CAUTION

Do not shift gears without releasing the throttle. Otherwise may cause damage to the engine or drive gear.

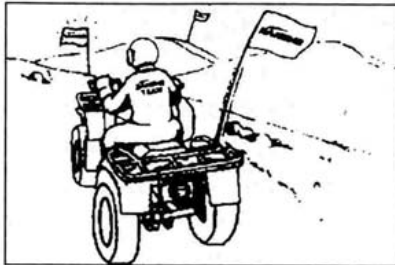

When slowing down or stopping, release the throttle and brake gradually. As you brake, shift to lower gear. Ensure that the engine has sufficiently slowed. Improper use of the brakes or shifting can cause the tires sliding to lose the control.

Must make the engine to slow down fully before engaging a lower gear.

Turning

Must make the turning practice in low speed before making a turn.

Turn your QUAD according to procedures in operation manual. Practice should be done before turning in high speed.

The turning speed should not be too high.

As you approach a curve, slow down and begin to turn the direction rod. Then put you gravity center on the footboard to the outside of the curve and lean your body inside. Make the engine to maintain an even speed when passing the curve. This maneuver will let the tire on the inside of the curve slip slightly. The turning practice should be in flat area with out any obstacles. Improper operation may make your QUAD to go straight. If the QUAD doesn't turn stop it and practise again. If the riding surface is loose and slippery

move your weight forward.

Once you have learn this technique you can turn your QUAD at higher speed.

The sudden acceleration, brake incorrect body position and too high speed will cause the QUAD to slip. If the QUAD slips while passing a curve and the QUAD machine leans inward, you should release the throttle and move your body gravity center to outside of the curve to avoid tipping over.

Remembenride at higher speed only after you are thoroughly familiar with the operation of your QUAD

Climbing slope

Don't ride on slope before you are very familiar with QUAD operation skill otherwise it will cause accidents. Neccessary practice is required when climbing the hill, move your body gravity center forward and operation manual.

Climb the hill according to the method in manual.
Climb the hill according to the method in manual.
Check carefully before climbing.

Do not drive on slippery and loose slope.

Transfer your body gravity center forward and avoid abrupt acceleration and shift.

Drive in low speed when climbing the hill.

WARNING

There may be other vehicles and persons on the other side of slope.

If your QUAD can not climb the slope turn round your QUAD.

Make turning practice according to procedures in operation manual. Do not make turn on slope. Be more careful when making a turn on slope. Be more careful when making a turn on slope and avoid to climb steep slope when possible when climbing the slope: Do not drive on depression and slippery slope and drive according to procedures in operation manual. Ensure the QUAD not to slip when stop it on slope.

The shift should be proper and speed shuld be stable when climbing slope losing traction force you should transfer the gravity center forward and brake the machine. Close the brake closing piece after stopping the machine.

If the machine slips backward

Transfer you gravity center backward;

Use front brake

Do not use rear brake

Close the brake closing piece after stopping the machine.

Riding downhill

Move your gravity center backward, when riding QUAD downhill your and grip steering bar and drive at low speed.

Note: The brake performance is very important. Whenever possible, ride your QUAD straight. Turing may cause the QUAD to tip over. Avoid too high speed so that you have time to deal with accident.

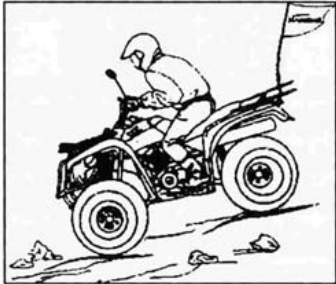

CAUTION

Practise the braking skill when decending the hill look over the terrain carefully before decending and transfer your body gravity center backward. Ride in low speed when decending the hill turning speed should not be too high when making a turn, and keep driving straight as far as possible.

Crossing depression

When crossing depression, balance your QUAD with body gravity center. You should be familiar with basic skills before crossing depression. Avoid to lose balance to cause accident.

Don't make a turn on a slope before grasping turning skill totally. You should be careful and cautious if making a turn on any slope.

When crossing procedure

Always follow proper prouclures in operation manual; Avoid slope with slippery or loose surface. Lean your gravity center in the slope direction.

Crossing through shallow water

The QUAD can be used to cross shallow water of maximum distance of 35cm. Check your path carefully

before crossing and avoid of ride where there is sharp drop off. Drive slowly and carefully. Pay attention that wet brakes may reduce brake ability. Check your brakes after leaving water. If necessary, apply them to let friction dry out the linings several times.

Riding over rough terrain

Be careful when riding on rough terrain when riding over terrain which may damage the QUAD lay your feet on the foot pedals to avoid jumping and loss of control.

Don't try to ride over big obstacles such as rock and tree on the road. Follow the proceduces in operation manual when riding over obstacles.

Slipping

The QUAD may lose control when driving on loose and slippery surface. Moving you gravity center forward is helpful to control the slipping of front wheels. when the rear wheel begin to slipsteer direction properly .Apply the brake only until you have stopped the slipping.

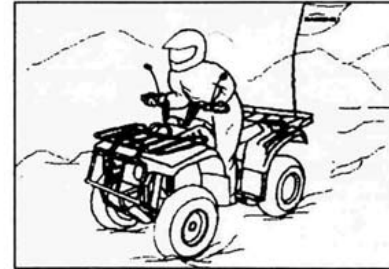

Practise safely control slipping at low speed, on very slippery surefaces, such as ice, drive slowly to avoid loss of control.

The above introduction is only for reference. Read it carefully and act according to circumstances.

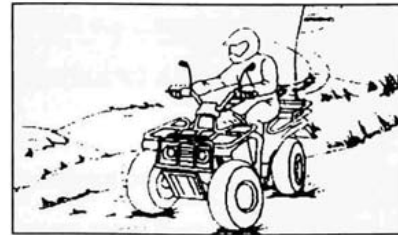

PERIODIC MAINTENANCE AND ADJUSTMENT

Periodic inspection, adjustment, and lubrication will keep your machine in the safety and most efficient condition. The points of machine inspection adjustment and lubrication are detailed in following.

NOTE

Turn off the engine when maintaining unless specified. Have a our dealer perform service if you are not familiar with maintenance.

Operation manual and tool kit

You are recommended to put this operation manual in the vinyl bag and lay it under the seat as shown. Put the tool kit and low pressure tire gauge in the storage case.

The maintaining information included in this manual is provided you with the necessary information for completing preventive maintenance and minor repairs by yourself. The tools provided in the tool kit are sufficient for this purpose except a torque wrench necessary to tighten nuts and bolts.

NOTE

If you do not have a required torque wrench during maintenance take you machine to a our dealer to check the torque settings and adjust them as necessary.

PERIODIC MAINTENANCE/LUBRICATION

ITEM	ROUTINE	INITIAL			EVERY	
		1 month	3months	6months	6months	1Year
Valves	Check valve clearance. Adjust if necessary.	○		○	○	
Spark plug	Check condition. Adjust gap and clean. Replace if necessary.	○	○	○	○	
Air filter	Clean. Replace if necessary.	Every 20-40 hours(more often in wet or dusty areas)				
Carburetor	Check idle speed/Starter operation. Adjust if necessary.		○	○	○	
Cylinder head breather system	Check breather hose for cracks or damage. Replace if necessary.			○	○	
Exhaust system	Check for leakage. Retighten if necessary. Repace gasket if necessary			○	○	
Spark arrester	Clean			○	○	
Fuel line	Check fuel hose for cracks or damage. Replace if necessary.			○	○	
Engine oil	Replace (Warm engine before draining).	○		○	○	
Engine oil filter	Clean	○		○		○
Engine oil strainer	Clean	○		○		○
Final gear oil	Check oil level/oil leakage. Replace.	○				○

PERIODIC MAINTENANCE/LUBRICATION

ITEM	ROUTINE	INITIAL			EVERY	
		1 month	3months	6months	6months	1Year
Brakes	Check operation. Adjust if necessary.	<input type="radio"/>		<input type="radio"/>	<input type="radio"/>	
Clutch	Check operation. Adjust if necessary.	<input type="radio"/>		<input type="radio"/>	<input type="radio"/>	
Wheels	Check balance/damage/run out. Replace if necessary.	<input type="radio"/>		<input type="radio"/>	<input type="radio"/>	
Wheel bearings	Check balance assembly for looseness/damage. Replace if damaged.	<input type="radio"/>		<input type="radio"/>	<input type="radio"/>	
Front and rear suspension	Check operation. Correct if necessary.			<input type="radio"/>	<input type="radio"/>	
Steering system	Check operation. Correct if necessary. Check toe-in.			<input type="radio"/>		<input type="radio"/>
Steering system	Adjust if necessary.	<input type="radio"/>	<input type="radio"/>	<input type="radio"/>	<input type="radio"/>	
Steering shaft	Lubricate every 6months. (use Li grease)			<input type="radio"/>	<input type="radio"/>	
Fittings and Fasteners	Check all chassis fittings and fasteners. Correct if necessary.	<input type="radio"/>	<input type="radio"/>	<input type="radio"/>	<input type="radio"/>	

Engine oil

1. Engine oil level measurement

a. Place the machine on a flat surface wram up the engine for several minutes and turn off it. Wait more than 10 minutes for the oil to drain back into the crankcase before checking the oil level.



①

1. Dipstick
2. Maximum level mark
3. Minimum level mark

b. Wipe the dipstick off with a clean rag. Insert the dipstick in the filler hole.

c. Remove the dipstick and inspect the oil level.

d. The oil level should be between maximum and minmum marks. If level is low, add oil to raise it to proper level.

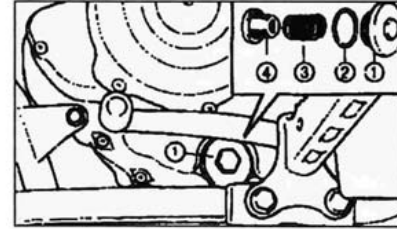

1. Drain plug
2. O-ring
3. Compression spring.
4. Oil strainer

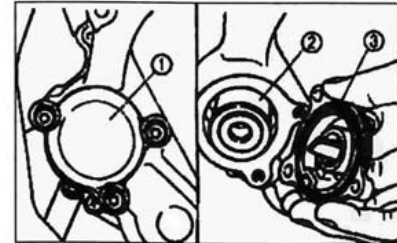

1. Oil filter cover
2. OH filter
3. O-ring

2. Engine oil replacement and oil filter element cleaning
- Place the machine in a flat surface. Warm up the engine for several minutes and turn off place a container under the engine. Remove the dipstick and open the drain plug to drain the oil.
 - Remove the oil filter cover and oil filter clean the oil strainer and oil filter with solvent.
 - Inspect the O-ring and replace if damaged.
 - Reinstall the oil filter, O-ring and oil filter cover. Replace the oil strainer compression spring, O-ring and drain plug. Then tighten the drain plug and filter cover bolts to the specified torque.

Tightening torque:

Drain plug (engine): 43Nm(4.3m.kg)

Filter cover bolt:10Nm(1.0m.kg)

- Add oil to the engine with oil and install the dipstick.

CAUTION

Be sure no foreign material enters the crankcase.

- Warm up the engine for several minutes at idle speed. Check for oil leakage when warming up.

CAUTION

If oil leakage is found, turn off the engine promptly and check for the cause.

Recommended oil: see page 11

Oil quantity:

Periodic oil change:

1.5L(1.3mpqt)

With oil filter replacement:

1.6L(1.4mpqt)

Total amount:

1.8L(1.6mpqt)

3.0il pressure inspection

- Wrap the cylinder with a cloth.

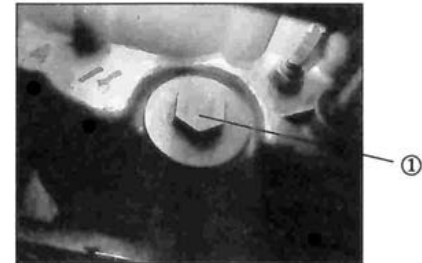

1 .oil gallery bolt

- b. Slightly loosen the oil gallery bolt in the cylinder head.
- c. Start the engine and keep it at idle speed until it begins to seep from the oil gallery bolt. If no oil comes out after one minute, stop the engine to find the cause.
- d. Restart the engine and check the oil pressure.
- e. After checking, tighten the oil gallery bolt to the specified torque 7Nm (0.7m.kg)
- f. Remember to inspect oil pressure after replacing the engine oil.

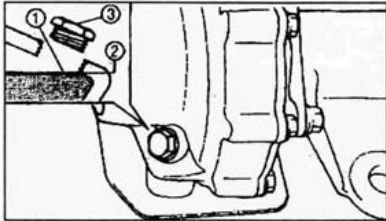

Lubrication oil of gear case

- a. Measurement of lubrication oil of gear case. Place the machine on a level place. Remove the oil filler bolt and check the oil level. It should be up to the brim of the hole. If it should be up to the brim of the

Hole. If the level is too low add oil to raise it to the proper level.

- b. Install the oil filler bolt and tighten to the specified torque: 23Nm(2.3.kg,17ft.lb)

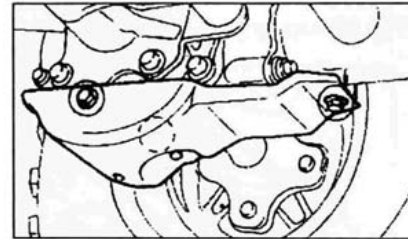

Lubrication oil replacement of gear case

- a. Remove the gear case cover.
- b. Place the machine on a flat surface.
- c. Place a container under the final gear case.
- d. Remove the oil filler bolt and the drain plug to drain the oil.
- e. Install the drain plug and tighten to the specified torque: 23Nm(2.3m.kg)
- f. Fill the gear case with oil.

Recommended oil:

SAE 80API"GL-4" Hypoid gear oil

Oil quality

Periodic oil change:

0.25L(0.21Impqt,)

Total amount:

0.27(0.23Imp qt.)

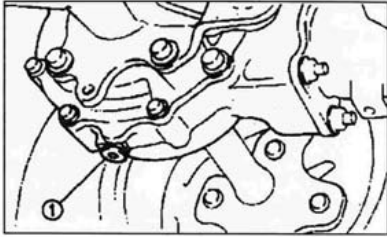

1.Drain plug

g. Install the filler bolt and tighten to the specified torque
:2.3Nm(2.3m.kg)

h. Check for oil leakage.If oil leakage is found, check
for the cause

i. Reinstall the final gear case cover.

Spark plug inspection

You should periodically remove and check the spark plug because heat and deposits will cause slow damage and erosion of the spark plug if electrode erosion is excessive, you should replace the spark plug with one of the propet type D7RTC

Before installing the new spark pulg measure the electrode gap with a feeler gauge and adjust to specifcation.

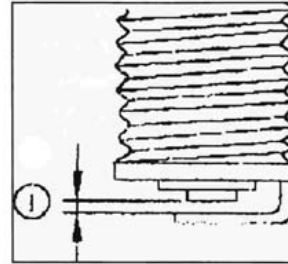

1. Spark plug gap
Spark plug gap:
0.6-0.7mm

When installing the spark pulg, generally clean the gasket surface and use a new gasket. Clean off any grime from the threads and tighten to specification.

Spark plug torque: 17.5Nm (1.75m.kg)

Air filter cleaning

There is a check hose at the bottom of the air filter case. If there is dust or water collected in this hose, empty the hose and clean the air filter element and air filter case.



1. Check hose



1. Remove the seat.
2. Remove the air filter case cover.

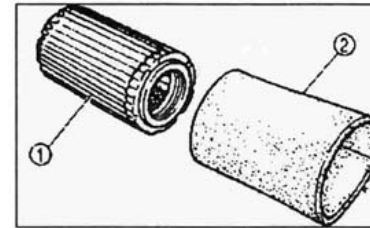
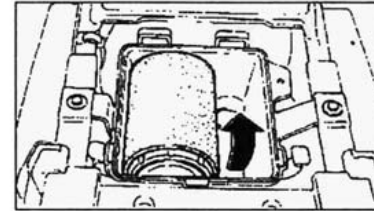

1. Air filter element
2. Foam cover
3. Remove the air filter element.
4. Remove the foam cover from the air filter element.
5. Tap the element lightly to remove most of the dust and dirt. Blow out the remaining dirt with compressed air. If the element is damaged, replace it.
6. Wash the foam cover gently thoroughly in water or solvent.

7. Squeeze the excess water or solvent out of the foam cover and let it dry. Do not twist the foam cover when squeezing it.
8. Check the foam cover if damaged, replace it.
9. Reinstall the foam cover to the air filter element.
10. Reinstall the removed air filter unit and parts removed.

CAUTION

The carburetor was set at the our factory after many tests. If the settings are disturbed by someone without sufficient technical knowledge, poor engine performance and damage may result.

CAUTION

Never run the engine with the air filter element removed. This will let unfiltered air enter.causing rapid wear and possible damage of engine. Additionally, operation without the filter element will weak the performance of carburetor and cause overheating of engine.

Carburetor adjustment

The idle speed may be performed by customer as a part of the routine maintenance.

Idle speed adjustment

1. Start the engine and warm it up for a few minutes at approximately 1,000 to 2,000 r/min, increase the speed of engine to 4000 to 5000r/min .
2. Set the specified idle speed by adjusting the throttle adjusting screw. Turn the screw into increase engine speed, and out to decrease engine speed. Specified idle speed: 1450-1550 r/min

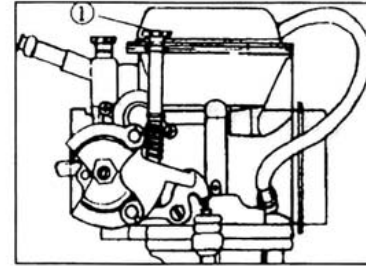

1. Throttle adjusting screw

Valve clearance adjustment

Incorrect valve clearance will result in improper fuel/air supply or engine noise. To prevent this, the valve clearance must be adjusted regularly, but the adjustment should be done by a professional maintenance technician.

Throttle lever adjustment

NOTE

Adjust the engine idle speed before adjusting the throttle lever.

1. Loosen the locknut.
2. Rotate the adjusting bolt until the throttle lever free play is 3-5mm(0.12-0.20in)
3. Tighten the locknut.

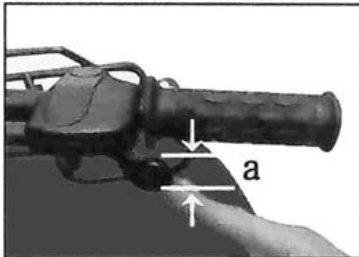

1. Adjusting bolt
2. Locknut a. 3-5mm (0.12-0.20in)

Front and rear brake shoe inspection

A wear indicator is mounted on each brake. The wear of brake shoe could be checked under the condition of disassembling brake. If the indicator reaches the wear limit line, ask a our Group dealer to replace the shoes as a set.

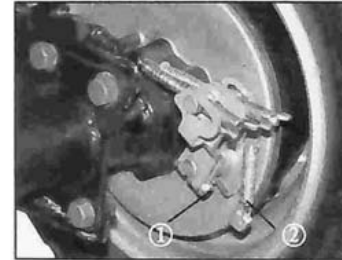

1. Wear indicator
2. Wear limit

Front brake lever free play adjustment

Inspect the front brake shoes before adjusting the brake.

The front brake lever free play should be adjusted to 5-7mm (0.2-0.3in) If the free play is incorrect, adjust as following steps:

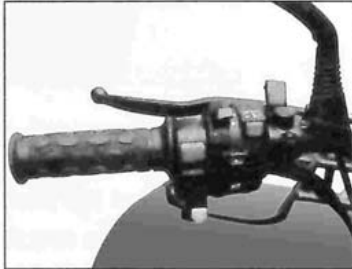

1. Locknut
2. Adjusting nut

1. Loosen the locknut and fully turn in the adjusting bolt of the front brake lever.
2. Make sure the cable joint of the balancer is straight when applying the brake. If not, rotate the adjusting nut at the front hubs until the cable joint becomes straight.



1. Adjusting nut (front hub)

3. Retate the adjusting bolt at the front brake lever to make the free play satisfy the requirement.
4. Tighten the locknut. After maintaining, pay attention to: Make sure the brakes operate smoothly and the free play meet the requirement.

Make sure the brakes do not skid.

Replacement of brake components requires professional knowledge.

These procedures should be done by our Group dealer.

Rear brake adjustment

1. Brake pedal

- a. Fully loosen the adjusting nut on the brake cable.
- b. Rotate the adjusting nut on the brake rod until free play is 20-30mm.

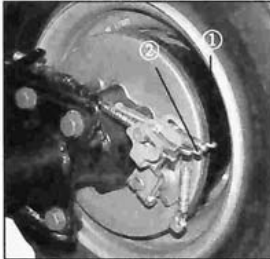

1. Brake cable adjusting nut
2. Brake rod adjusting nut

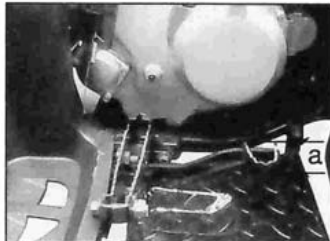

- a. 20-30mm

2. Brake lever

- a. Loosen the locknut and fully turn in the adjusting nut on the handlebar.
- b. Turn in the adjusting nut on brake cable to get a gap of 0-1 mm between the lever and pin of pivot.

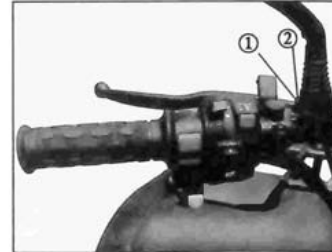

1. Locknut
2. Adjusting nut

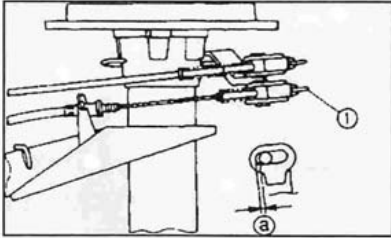

1. Brake cable adjusting bolt a. 0-1mm(0-0.4 in)
- c. Rotate the adjusting nut until free play is 5-7mm.
- d. Tighten the locknut.

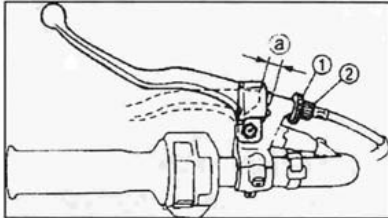

1. Locknut
2. Adjusting nut a. 5-7mm

After maintaining, pay attention to: Make sure the brakes operate smoothly and the free play is correct. Make sure the brakes do not skid. Replacement of brake components requires professional knowledge. These procedures should be done by our Group dealer.

Clutch adjustment

1. Loosen the lock nut
2. Slowly rotate the adjusting bolt counterclockwise until resistance is felt then, rotate it by 1/8 turn clockwise, i.e. 45°.

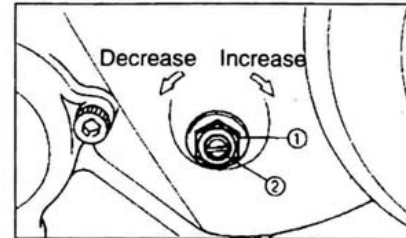

1. Locknut
2. Adjusting bolt
3. Tighten the locknut to specified value .Tightening torque:15Nm(1.5m.kg)

NOTE

Turn the adjusting bolt counterclockwise to decrease the clutch free play and turn it clockwise to increase the free play.

cable inspection and lubrication

The damage of outer covering of control cable can cause corrosion, fray or kink of cable. Operation of cables could be strictly executed, which could cause an accident or injury.

Inspect cable frequently and replace damaged cables. Lubricate the inner cables and the cable joints. If the cables do not operate smoothly, ask a our Group dealer to replace them.

Recommended lubricant: SAE 10W30

Steering vertical tube lubrication

Use a grease gun to lubricate the pivots. Revommended lubricant: Lithium-base grease

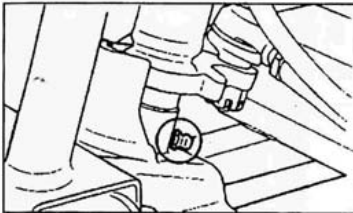

Wheel removal

1. Lift the wheel by placing a suitable support under the frames.
2. Remove the nut on the wheel.
3. Remove the wheel assembly.



Wheel installation

When installing the wheel reverse the removal procedure. Pay attention to the following points:

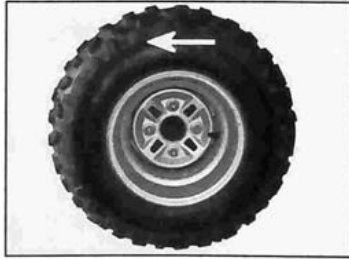

1. Arrow mark

1. The arrow mark "↶" on the tire must point to the rotation direction of the wheel.
2. Tapered wheel nuts are used for both front and rear wheels. Install tapered side of the nut towards the wheel.
3. Tighten the wheel nut.

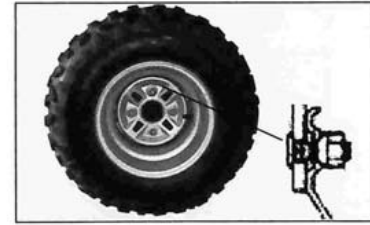

1. Tapered nut

Wheel nut torque:

Front wheel: 55Nm (5.5m.kg)

Rear wheel: 55Nm (5.5m.kg)

Battery

WARNING

Avoid contact with skin, eyes or clothing. Always shield eyes when working near batteries. Keep out of reach of children.

Use and maintenance

1. Don't remove electrolyte cover after enclosed battery being used. Please obey the operation instruction on battery to use the battery.
2. If QUAD is suspended from use for a month or much longer time, remove the battery and store in a cool and dark place, charge fully before reusing.
3. If the battery is stored over the above mentioned time, check the voltage at least one month. Charge the battery when the voltage is lower than 12 V.

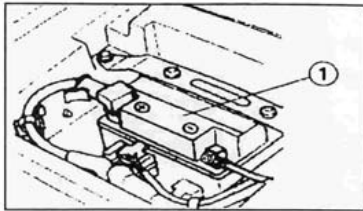

1 .Battery

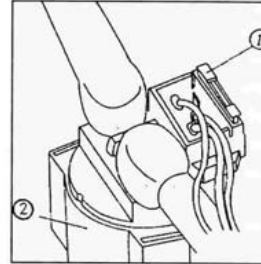

1. Main fuse
2. Start relay

Fuse replacement

1. The fuse case is put under the seat.
2. If the fuse is blown, switch off the main switch and replace with a new fuse of the same specification. If the fuse immediately blows again consult a our Group dealer.

Specified fuse: 20A

CAUTION

To prevent accidental short-circuiting, switch off the main switch when checking or replacing a fuse.

Replacing the headlight bulb

If the headlight bulb burns out, replace the bulb as following steps:

- 1.Remove the headlight cover.
- 2.Remove the cover and rotate the bulb holder counterclockwise and remove the defective bulb.



1.Headlight



1. Cover (x2)



1.Bulb holder

WARNING

Wait for the bulb to cool before removing it. 3. Install a new bulb to the bulb holder.

4. Reinstall the cover and headlight cover. Adjust the headlight beam if necessary.



①

Spark arrester cleaning

Select a well-ventilated area free of combustible materials and make sure the exhaust and silencer are cool.

1. Remove the bolt.
2. Start the engine, block the end of silencer with a dowel, which will increase the speed about twenty times by momentarily producing exhaust system back pressure.
3. Stop the engine and cool the exhaust pipe.
4. Install the bolt and tighten it.

CLEANING AND STORAGE

CLEANING

General speaking thorough cleaning of your QUAD Will improve its running performance and prolong the service life of many components.

1. Before cleaning the QUAD:
 - a. Block off the exhaust pipe with plastic bag or strong rubber band to prevent water entry.
 - b. Make sure the spark plug and all filler caps are properly installed.
2. If the engine case is excessively dirty, wash with degreaser. Do not use degreaser for wheel axles.
3. Rinse the dirt and remove oil dirt on the soft hose.

CAUTION

Excessive water pressure may cause water seepage and deterioration of wheel bearings, brakes, transmission seals and electrical equipment.

4. When rinsing dirty material for many times, use warm water and mild, detergent-type soap. Use old toothbrush or bottle brush to wash hard-to-get-at places.
5. After cleaning QUAD with clean water immediately dry all surfaces with a chamois clean towel or soft absorbent cloth.

6. Clean the seat with a vinyl upholstery cleaner to keep the cover pliable and glossy.

7. Apply automotive type wax to all chrome plated surfaces. Avoid use combination cleaner -waxes- After using abrasives to protect scratched surface, let the engine idle for several minutes.

After washing the brakes let engine brake several times at slow speeds to dry the linings.

B. Storage

Long term storage (60 days or more) of your QUAD will require some protective procedures to prevent QUAD from damage. After thoroughly cleaning the QUAD, adopt the following protective measures:

1. Add fresh fuel into fuel tank.
2. Add one tablespoon of SAE 10W30 or 20W40 motor oil in the spark plug. Ground the spark plug wire and run the engine over several times to coat the cylinder body with oil.
3. Lubricate all control cables.
4. Elevate the engine body to raise all wheels off the ground.
5. Seal with plastic bag over the exhaust pipe outlet to prevent moisture from entering.
6. If storing QUAD in a humid or salt-air atmosphere, cover all exposed metal surfaces with a light plastic

film of oil. Do not apply oil to any plastic parts or the seat cover.

7. Take out the battery and store it in a dry place. The battery should be stored in the place where the ambient temperature should be 30°C maximum and 0°C minimum.

MAIN DATA AND SPECIFICATIONS

Item	specification	Item	specification
Dimension:		Engine oil:	
Overall length	1940mm	Periodic oil change	1.5L
Overall width	1050mm	With oil filter replacement	1.6L
Overall height	1160mm	Total amount	1.8L
Seat height	810mm	Total amount of gear oil	0.27L
Wheel base	1160mm	Main fuel tank capacity	12L
Minimum ground clearance	1160mm	Reserve fuel tank capacity	1.6L
Minimum turning radius	2900mm	Carburetor:	
Basic weight:		Type	Vacuum film piece type
With oil and full fuel tank	220kg	Spark plug type	D7RTC
Engine	Air cooled,4-stroke,single-cylinder	Spark plug gap	0.6-0.7mm
Displacement	229.6ml	Clutch type	Wet.centrifugal automatic
Bore x Stroke	71 x 58mm	Transmission:	
Compression ratio	8.7:1	Primary reduction system	Spur gear
Starting system	Electric starter or recoil starter	Primary reduction ratio	73/22(3.318)
Lubrication system	Pressure splash	Secondary reduction system	Shaft drive
		Secondary reduction ratio	19/18 x 46/11 (4.414)
		Transmission type	Constant mesh,5-speed forward-speed reverse
		Operation	left foot operation

MAIN DATA AND SPECIFICATIONS

Item	specification	Item	specification
Gear ratio:		Suspension	Supporting rod
1st	34/12(2.833)	Front	Rotary rod
2nd	34/19(1.789)	Rear	
3rd	29/22(1.318)	Shock absorber:	
4th	26/25(1.040)	Front	Spring/oil damper
5th	23/28(0.281)	Rear	Spring/oil damper
Reverse	73/22 x34/12 X 19/18 X 46/11(41.5)	Wheel travel:	
Frame		Front	135mm
Frame type	Steel tube	Rear	135mm
CasterA angle	4°	Electrical:	
Trail	20mm	Ignition system	CDI
Tire:		Generator system	A.C.Magneto
Type	Vacuum	Battery type/voltage,capacity	12N14-BS/12V.14AH
Size:Front	AT22 x 7-10	Headlight	12v,30W/30Wx2
Size:Rear	AT22X 10-10	Taillight	12V.10WX 1
Brake:		Neutral indicator	12V.3W X 1
Front brake type	Drum brake	Reverse indicator	12V.3W X 1
Operation	Right hand operation	Hight beam indicator light	12V.3W X 1
Rear brake type	Drum brake		
Operation	Left hand and right foot operation		

MAINTENANCE RECORD

Maintenance times, receipts of purchased components and assembly will be required to be recorded, which should be done according to the warranty. The chart below only acts as maintenance record, not as maintenance proof:

MAINTENANCE INTERVAL TIME	DATE OF MAINTENANCE	DRIVING MILEAGE	SERVICING DEALER NAME AND ADDRESS	REMARKS
1 Month				
3Months				
6Months				
12Months				
18Months				
24Months				
30Months				
36Months				
42Months				
48Months				
54Months				
60Months				

ELECTRIC WIRING DIAGRAM

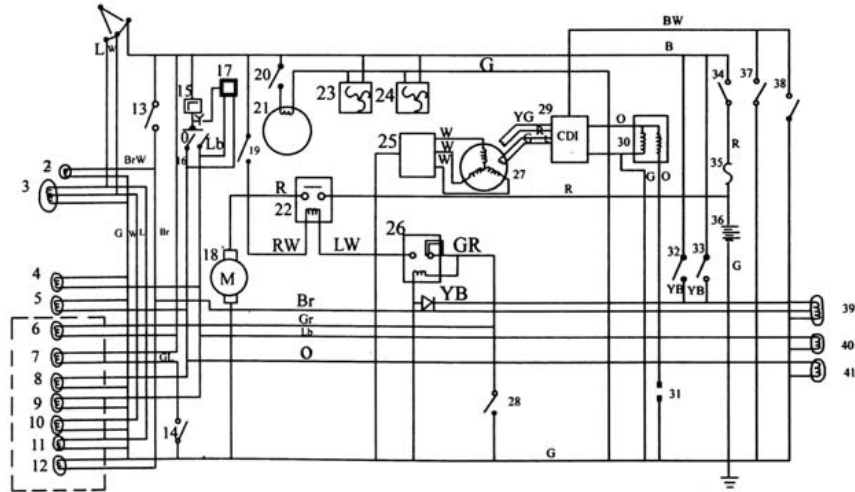

- | | | | |
|------------------------------|------------------------------|--------------------|------------------------------|
| 1. Headlight switch | 12. Meter background light | 22. Relay | 33. Foot brake clutch switch |
| 2. Position light | 13. Position light switch | 23. Fan | 34. Total switch |
| 3. Headlight | 14. Reverse indicator switch | 24. Fan | 35. Fuse |
| 4. Fr.R.winker | 15. Flasher | 25. Rectifier | 36. Battery |
| 5. Fr.L.winker | 16. Turning signal switch | 26. Relay | 37. Total flameout switch |
| 6. Neutral indicator | 17. Emergency light switch | 27. Magneto | 38. Flameout switch |
| 7. Reverse gear indicator | 18. Starting motor | 28. Neutral switch | 39. Tail light |
| 8. L.winker indicator | 19. Ignition switch | 29. CDI | 40. Rr.R.winker |
| 9. R.winker indicator | 20. Horn switch | 30. Ignition coil | 41. Rr.L.winker |
| 10. Short distance indicator | 21. Horn | 31. Spark plug | |
| 11. Long distance indicator | | 32. Handle brake | |

GASGAS

RECOMIENDA EL USO DE ACEITE:
RECOMMENDS THE USE OF OIL:
RECOMMANDE L'USAGE DE L'HUILE:
CONSIGLIA L'USO D'OLIO:



GASGAS

Mayo / May / Mai / Maggio 2005



PU010538046

C/ UNICEF nº 17 · Poligon Industrial Torremirona · 17190 Salt (Girona) SPAIN · Tel: +34 902 47 62 54 Fax: +34 902 47 61 60
E-mail: officegg@gasgasmotos.es / partsgg@gasgasmotos.es